

K901718 Dream-G LPG HP pressure reducer maintenance

Disconnect the electrical connection (I) and make sure that the manual valve on the tank is closed. Disconnect the LPG rubber hose (V) (vent out the remaining gas in an open environment). Remove then the water hoses (III and IV) and the vacuum hose (VI).

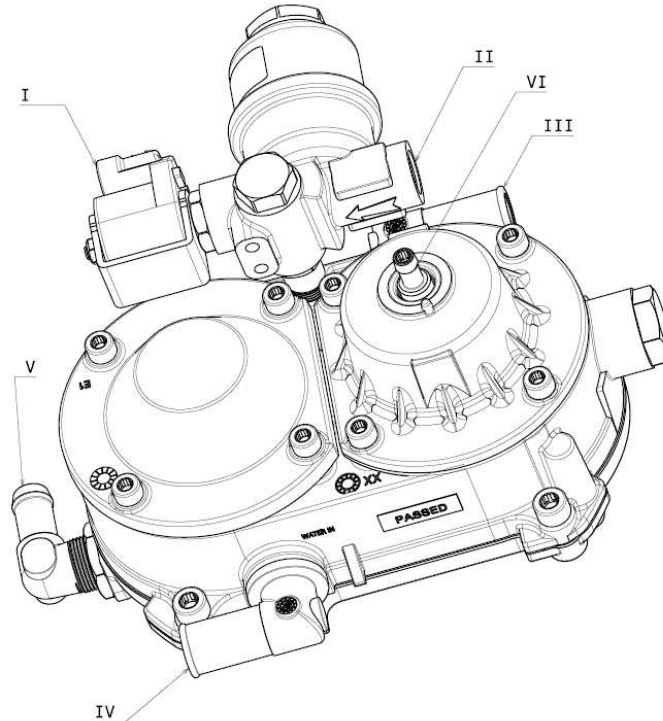

Fig. 1

While stopping the base nut with a 14mm Allen wrench, use another 16mm Allen wrench to unscrew (20Nm) the hex nut on top of filter (Fig.2). Once loose, pull out the filter: there's no need to disconnect LPG copper pipe (II). Now the pressure regulator is free to be removed from the engine bay and placed on a flat surface.

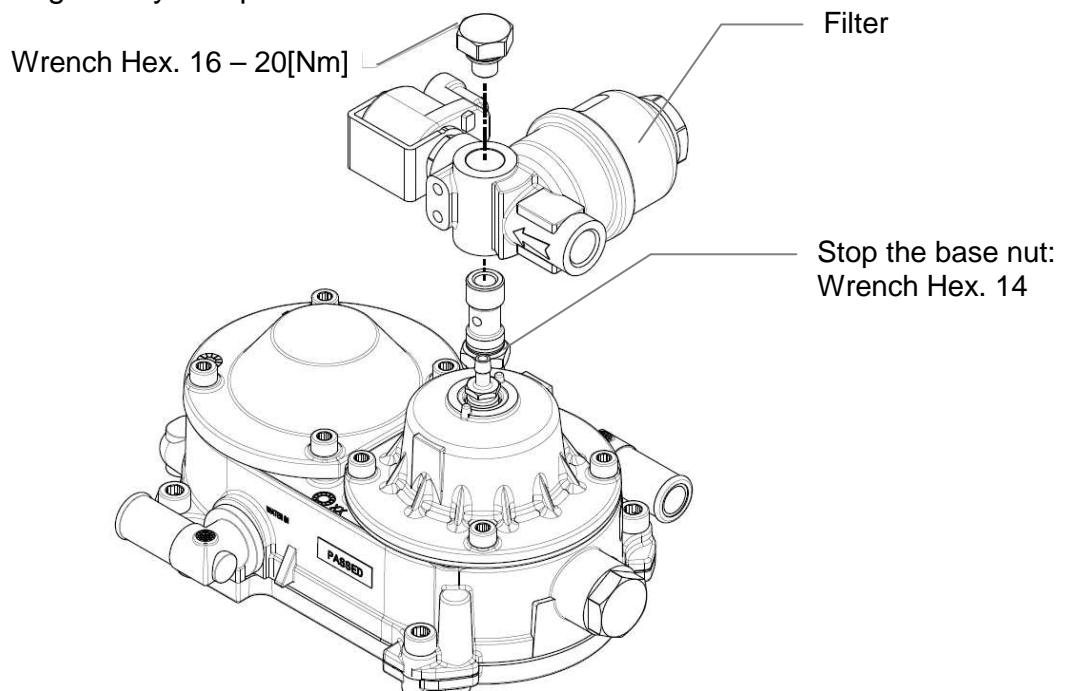

Fig. 2

FIRST STAGE

Use a 4mm Allen key to unscrew (5Nm) the four hex bolts of the first stage's cover (Fig.3), taking care that the internal springs will push away the cover; once the cover is removed, take out the big spring, the aluminium plate and the small spring that are standing inside.

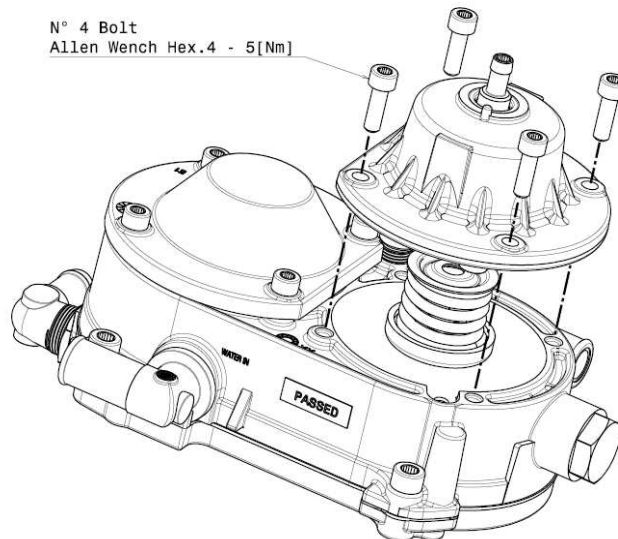

Fig. 3

The safety spring assy is now exposed (Fig.4) and should be disassembled: stop the internal 3mm hex with an Allen key, while unscrewing the outside 14mm nut with an Allen wrench.

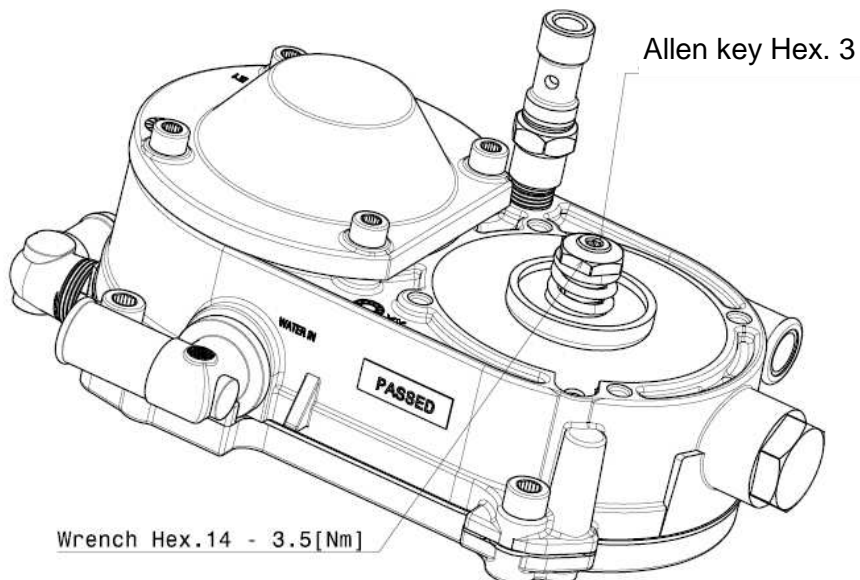

Fig. 4

Now the assy is loose (Fig. 5): you can remove the 14mm hex nut and the safety spring, then pull out the plastic centering plate and the rubber membrane (Part number 01815). The membrane should be replaced with new one.

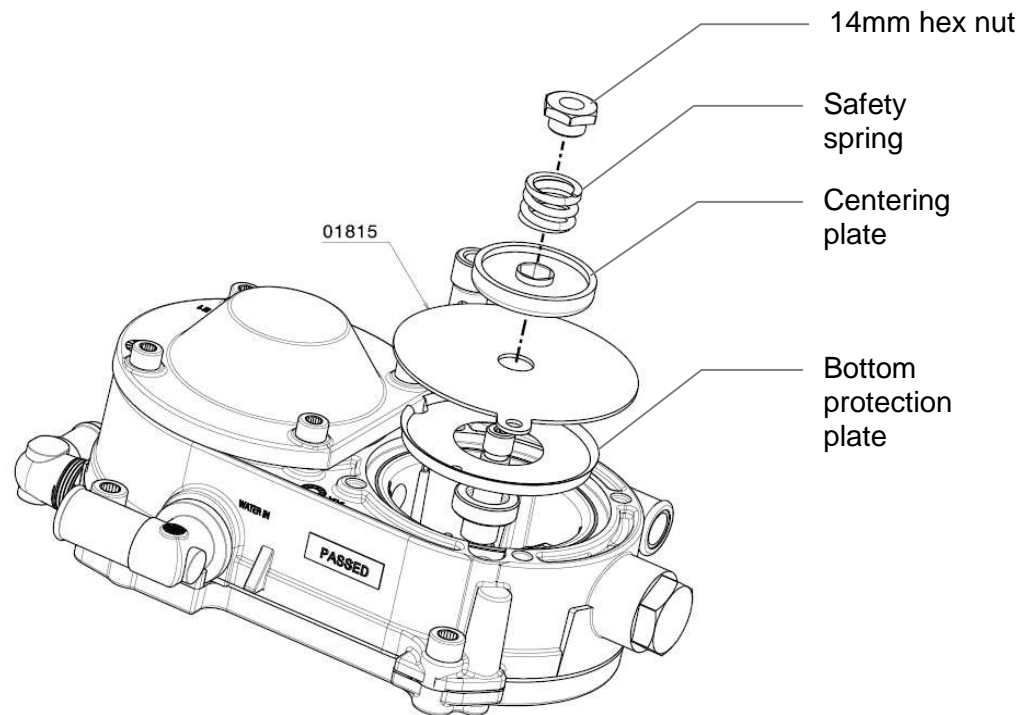

Fig. 5

Take note of the orientation of the membrane and the centering plate.

Remove the bottom protection plate: the first stage leverage (E) is now exposed (Fig. 6). Use a PH1 Phillips screwdriver to unscrew (3Nm) the two screws (D), then pull out the high pressure shutter (C). Remove the small rubber disk (A) off the tip of the shutter and replace with new one (part number 01599). Visually check (with out disassembling) that high pressure brass seat (F) is free of dents or defects, which could affect the sealing.

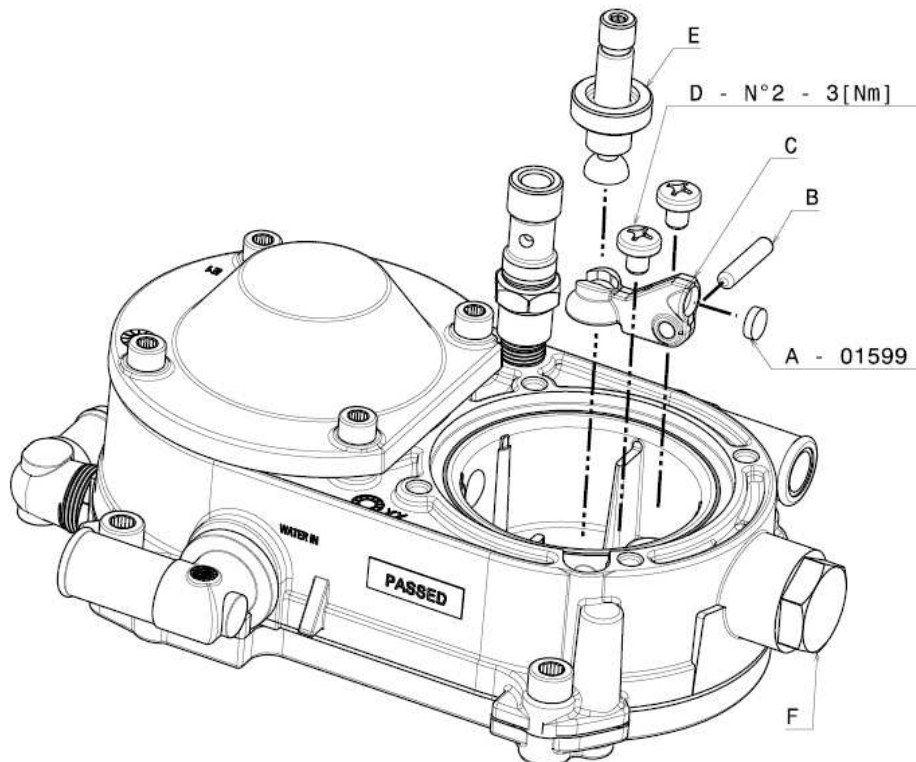

Fig. 6

When reassembling the safety spring assy, pay attention to the centering plate (Fig.5), which has a centering rib that should be aligned with the membrane. The 14mm hex nut that closes the safety spring assy should be tightened to 3,5Nm.

SECOND STAGE

Use a 4mm Allen key to unscrew (5Nm) the four hex bolts of the second stage's cover (Fig.7); then remove the cover.

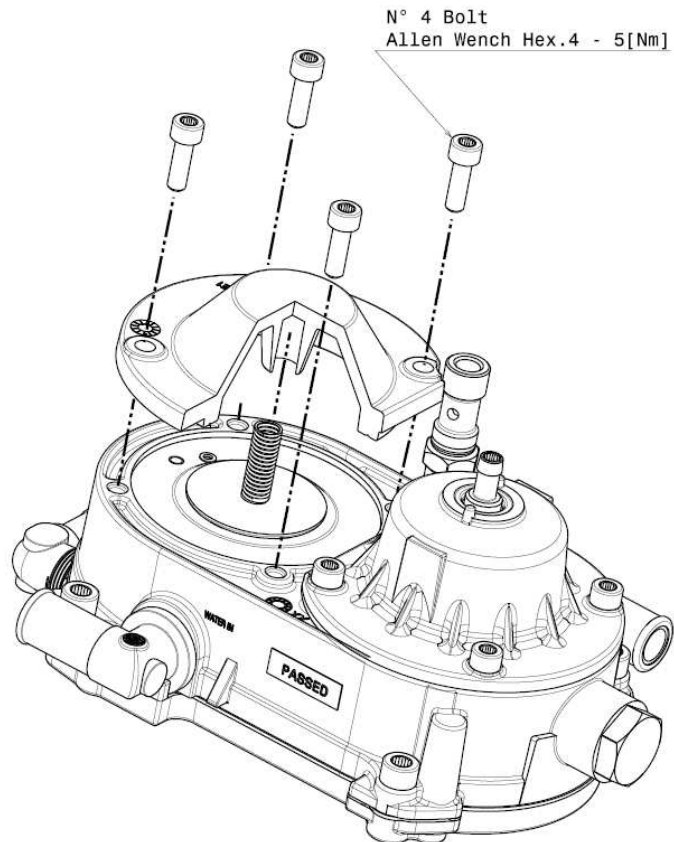

Fig. 7

Remove the spring (B) that's standing on top of the rubber membrane (Fig.8), then replace the membrane (A) with new one (part number X0039).

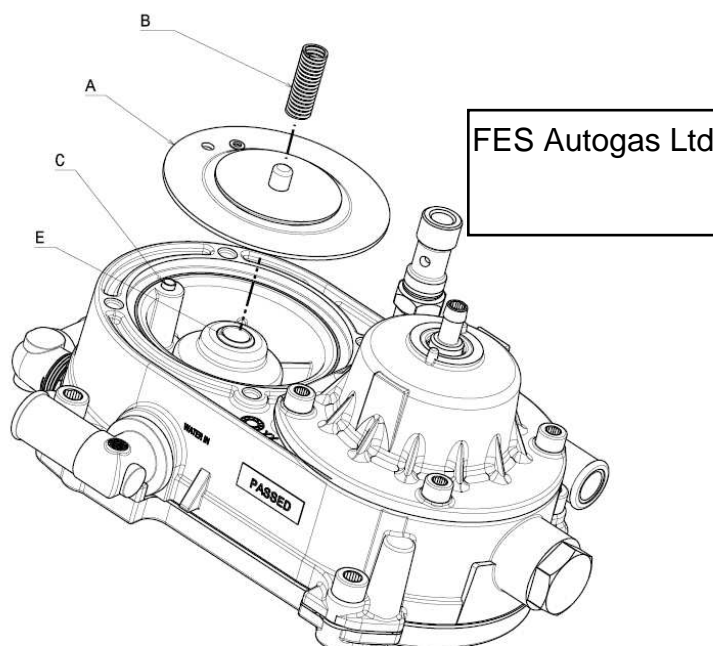

Fig. 8

When reassembling, pay attention to the membrane, which should be properly aligned with the centering rib (E) and the small tube (C).

When reassembling the cover, make sure that the spring (B) properly slides into the guide, inside the cover.